

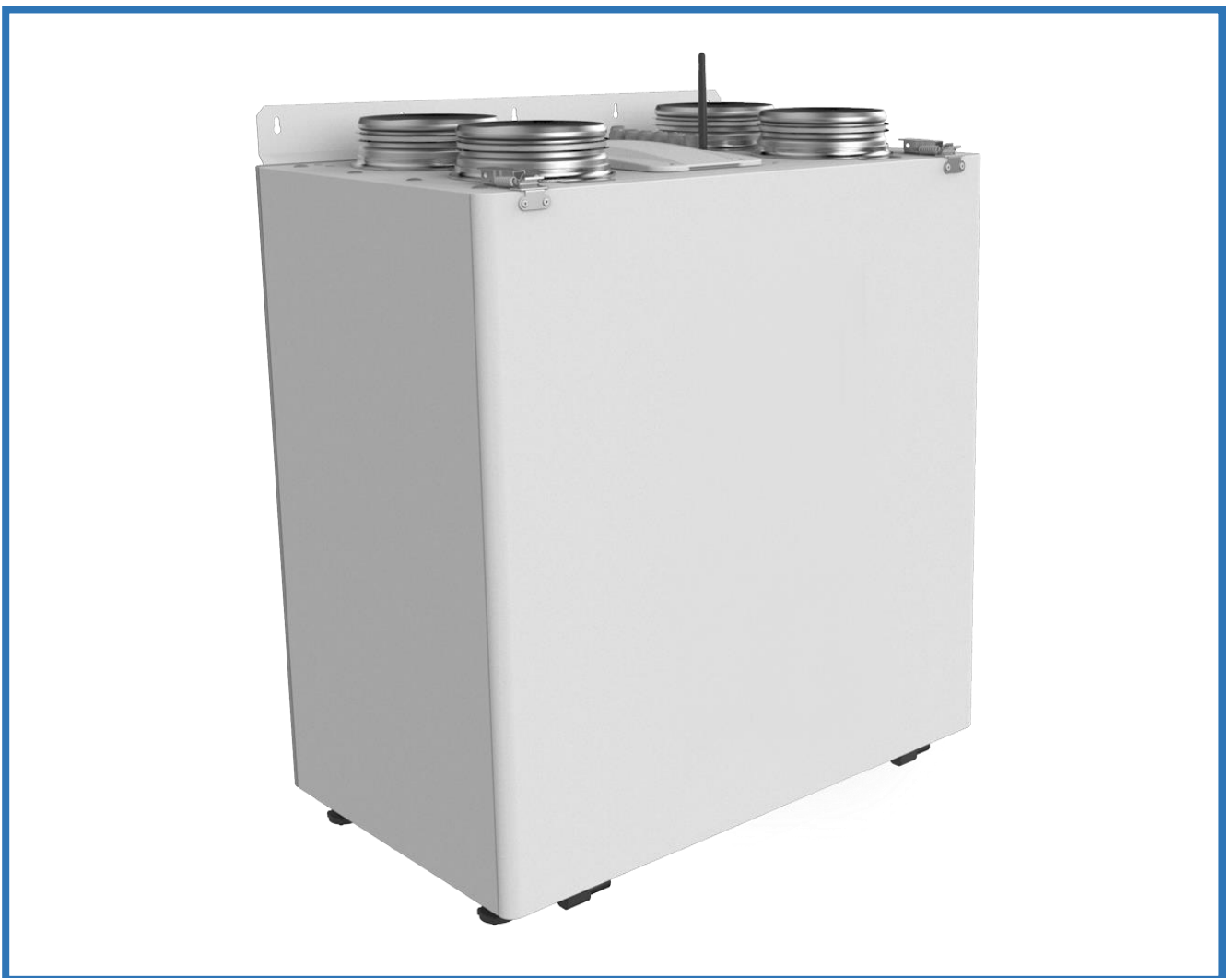

USER'S MANUAL

Heat and energy recovery air handling unit



Orca Energija d.o.o.

This user's manual is a main operating document intended for technical, maintenance, and operating staff. The manual contains information about the purpose, technical details, operating principle, design, and installation of the MAXI (E) 160/350/550 WiFi unit (-s) and all of its (their) modifications. Technical and maintenance staff must have theoretical and practical training in the field of ventilation systems and should be able to work in accordance with workplace safety rules as well as construction norms and standards applicable in the territory of the country. The information in this user's manual is correct at the time of the document's preparation. The Company reserves the right to modify the technical characteristics, design, or configuration of its products at any time in order to incorporate the latest technological developments. No part of this publication may be reproduced, stored in a retrieval system, or transmitted, in any form or by any means in any information search system or translated into any language in any form without the prior written permission of the Company.











CONTENT









1	SAFETY REQUIREMENTS	1
1.1	Unit installation and operation safety precautions	1
2	PURPOSE	3
3	DELIVERY SET	4
4	TEHNICAL DATA	5
5	DESIGN AND OPERATING PRINCIPLE	7
5.1	Operating principle	7
5.2	UNIT OPERATION MODES	8
5.2.1	Heat Recovery mode	8
5.2.2	Summer Cooling mode	9
6	INSTALLATION AND SET-UP	10
6.1	HV2 humidity sensor installation and connection for the maxi 350/550 units	10
6.2	HV2 humidity sensor installation and connection for the maxi 160 units	10
6.3	Service side change	12
6.4	Unit installation	13
6.4.1	Unit wall mounting	13
6.4.2	Unit floor mounting	13
6.5	Condensate drainage	14
6.6	Conection to power mains	14
6.7	External connections diagram for the maxi 160	15
6.8	External connections diagram for the maxi 350/550	16
7	TECHNICAL MAINTENANCE	17
7.1	Possible reasons and troubleshooting	18
8	STORAGE AND TRANSPORTATION REGULATIONS	19
9	MANUFACTURER’S WARRANTY	20
9.1	Certificate of acceptance	21
9.2	Seller informations	21

1 SAFETY REQUIREMENTS

- Please read the user's manual carefully prior to installing and operating the unit.
- All user's manual requirements as well as the provisions of all the applicable local and national construction, electrical, and technical norms and standards must be observed when installing and operating the unit.
- The warnings contained in the user's manual must be considered most seriously since they contain vital personal safety information.
- Failure to follow the rules and safety precautions noted in this user's manual may result in an injury or unit damage.
- After a careful reading of the manual, keep it for the entire service life of the unit.
- While transferring the unit control, the user's manual must be turned over to the receiving operator.

1.1 Unit installation and operation safety precautions

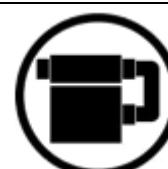
	Unpack the unit with care.		Disconnect the unit from power mains prior to any installation operations.
	The unit must be grounded!		While installing the unit, follow the safety regulations specific to the use of electric tools..
	Do not change the power cable length at your own discretion. Do not bend the power cable. Avoid damaging the power cable. Do not put any foreign objects on the power cable.		Do not lay the power cable of the unit in close proximity to heating equipment.
	Do not use damaged equipment or cables when connecting the unit to power mains.		Do not operate the unit outside the temperature range stated in the user's manual. Do not operate the unit in aggressive or explosive environments.
	Do not touch the unit controls with wet hands. Do not carry out the installation and maintenance operations with wet hands..		Do not wash the unit with water. Protect the electric parts of the unit against ingress of water.

	Do not store any explosive or highly flammable substances in close proximity to the unit.		When the unit generates unusual sounds, odour, or emits smoke, disconnect it from power supply and contact the Seller.
	Do not open the unit during operation.		Do not direct the air flow produced by the unit towards open flame or ignition sources.
	Do not block the air duct when the unit is switched on.		In case of continuous operation of the unit, periodically check the security of mounting.
	Do not sit on the unit and avoid placing foreign objects on it.		Use the unit only for its intended purpose.
	Do not allow children to operate the unit..		Disconnect the unit from power mains prior to any technical maintenance.



THE PRODUCT MUST BE DISPOSED SEPARATELY AT THE END OF ITS SERVICE LIFE.
DO NOT DISPOSE THE UNIT AS UNSORTED DOMESTIC WASTE.

2 PURPOSE

The unit is designed to ensure continuous mechanical air exchange in houses, offices, hotels, cafes, conference halls, and other utility and public spaces as well as to recover the heat energy contained in the air extracted from the premises to warm up the filtered stream of intake air. The unit is not intended for organizing ventilation in swimming pools, saunas, greenhouses, summer gardens, and other spaces with high humidity.

Due to the ability to save heating energy by means of energy recovery, the unit is an important element of energy-efficient premises. The unit is a component part and is not designed for stand-alone operation.

It is rated for continuous operation.

Transported air must not contain any flammable or explosive mixtures, evaporation of chemicals, sticky substances, fibrous materials, coarse dust, soot and oil particles or environments favourable for the formation of hazardous substances (toxic substances, dust, pathogenic germs).



THE UNIT SHOULD NOT BE OPERATED BY CHILDREN OR PERSONS WITH REDUCED PHYSICAL, MENTAL, OR SENSORY CAPACITIES, OR THOSE WITHOUT THE APPROPRIATE TRAINING.
THE UNIT MUST BE INSTALLED AND CONNECTED ONLY BY PROPERLY QUALIFIED PERSONNEL AFTER THE APPROPRIATE BRIEFING.
THE CHOICE OF UNIT INSTALLATION LOCATION MUST PREVENT UNAUTHORIZED ACCESS BY UNATTENDED CHILDREN.

3 DELIVERY SET

Name	Number
Air handling unit	1 pc.
User's manual	1 pc.
Packing box	1 pc-

4 TECHNICAL DATA

The unit is designed for indoor application with the ambient temperature ranging from +1 °C up to +40 °C and relative humidity up to 80 %.

In order to prevent condensation on the internal walls of the units, it is necessary that the surface temperature of the casing is 2-3 °C higher than the dew point temperature of the transported air.

The unit is rated as a Class I electrical appliance.

Hazardous parts access and water ingress protection rating:

- IP22 for the unit connected to the air ducts
- IP44 for the unit motors

The unit design is constantly being improved, thus some models may be slightly different from those described in this manual.

MODEL	160 VB EC		350 VB EC		550 VB EC
Supply voltage [V/50 (60) Hz]	1~220-240				
Maximum fan power [W]	57		169	178	337
Maximum unit current (without a heater) [A]	0.5		1.3	1.4	2.4
Maximum air flow [m ³ /h]	200		420	450	690
RPM [min ⁻¹]	3770		3200		2860
Sound pressure level at 3 m distance [dBA]	24	22	28		26
Transported air temperature [°C]	-25 (+40)				
Casing material	Painted steel				
Insulation, mineral wool [mm]	20	40			
Filtering class of the extract filter	G4				
Filtering class of the supply filter	F7 (optionally G4)				
Connected air duct diameter [mm]	125		160	200	
Weight [kg]	44		64	82	
Heat recovery efficiency [%]	76-92		85 -92		84-92
Heat exchanger type	Counter-flow				
Heat exchanger material	Polystyren				
SEC class	A+				

The MAXI E units are equipped with an enthalpy heat exchanger and do not require condensate drainage.

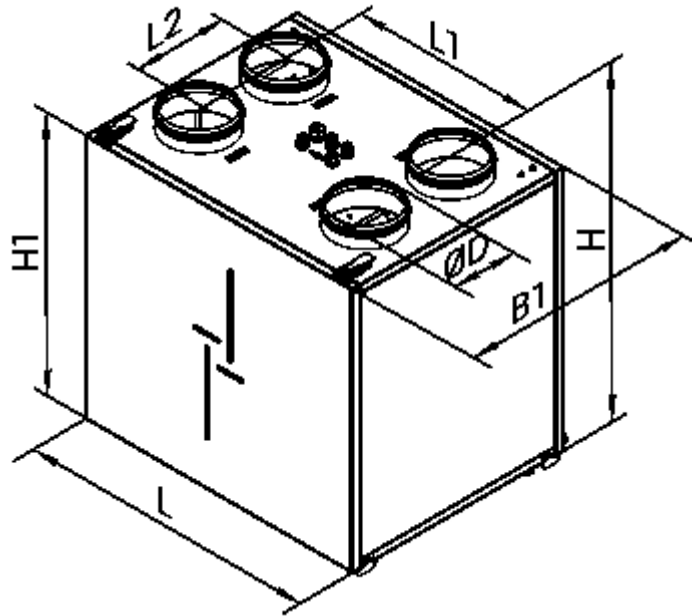

Model	Dimensions [mm]									
	Ø D	Ø D1	B	B1	H	H1	L	L1	L2	
MAXI 160 VB EC	125	18	340	330	665	550	600	388	143	
MAXI 350 VB EC	160	18	600	583	760	675	730	426	230	
MAXI 550 VB EC	200	18	550	720	760	675	823	498	288	

5 DESIGN AND OPERATING PRINCIPLE

5.1 Operating principle

The unit has the following operating principle: warm stale extract air from the room flows into the unit where it is filtered by the extract filter, then air flows through the heat exchanger and is exhausted outside by the extract fan. Cold fresh air from the outside flows into the unit, where it is cleaned by the supply filter. Then the air flows through the heat exchanger and is directed to the room with the supply fan. Heat energy of warm extract air is transferred to clean intake fresh air from the outside and warms it up. The air flows are fully separated while flowing through the heat exchanger. Heat recovery minimizes heat losses, which reduces the cost of space heating in the cold season.

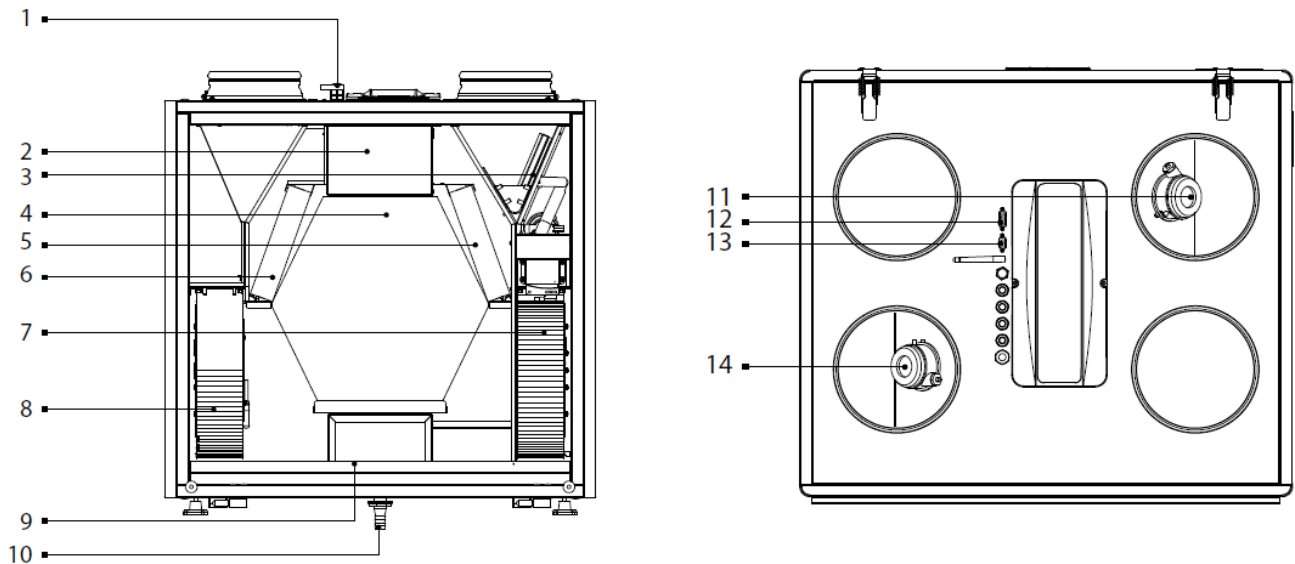

1 – cable glands; 2 – control unit; 3 – bypass damper; 4 – counter-flow heat exchanger; 5 – extract filter; 6 – supply filter; 7 – supply fan; 8 – extract fan; 9 – drain pan; 10 – drain pipe; 11 – extract filter differential pressure switch (only for the MAXI (E) 550); 12 – NKP duct electric preheater connector; 13 – duct electric reheater connector; 14 – supply filter differential pressure switch (only for the MAXI (E) 550).

The air handling unit is equipped with a hinged front service panel for repair and maintenance operations. The removable service panel design enables to change the service side location. The control unit is accessible for installation and wiring operations through the inspection door on top of the unit. The power cable and ground cable are connected to the control unit via the cable glands.

The bypass damper is open or closed depending on operation mode of the unit.

The MAXI (E) 550 VB EC units are equipped with differential pressure switches for filter contamination control. Access to the pressure switches is provided through the inlet and outlet spigots.

The difference between the supply and extract air flow temperature leads to condensate generation in the MAXI 160/350/550 V(1)B EC units. Condensate is collected in the drain pan and is removed outside through the drain pipe.

The MAXI E 160/350/550 V(1)B EC units are equipped with a heat exchanger with an enthalpy membrane and do not require condensate drainage.

Accessories for the unit are available on a separate order.

- Humidity sensor. The HV2 sensor in the MAXI (E) 160/350/550 WiFi models is connected to the controller. The HR-S sensor is connected to the controller. The unit with an installed humidity sensor maintains a set indoor humidity point. As the extract air humidity rises above the set point, the system automatically switches to the maximum speed. As the humidity drops down below the set point the unit returns to the previous mode.

- **CO₂ sensor** (connected to the controller). Designed for indoor carbon dioxide concentration measurement and respective air capacity regulation through the control output signal to the fan.
- **VOC sensor** (connected to the controller). Qualitative assessment of air saturation with contaminants (cigarette smoke, exhaled air, solvent and detergent vapours). The sensor sensitivity can be adjusted with regards to the expected maximum level of air pollution. Enables on-demand ventilation which results in considerable energy savings as air is exchanged only upon reaching the preset level of pollution.
- **NKP duct preheater** (for the MAXI (E) 160/350/550). The heater maintains the duct air temperature at a point that prevents the heat exchanger freezing. Heater installation and connection to the unit are described in the heater user's manual.
- **NKD duct reheater** (for the MAXI (E) 160/350/550). The heater maintains a room temperature set by the temperature sensor. Heater installation and connection to the unit are described in the heater user's manual.

5.2 UNIT OPERATION MODES

5.2.1 Heat Recovery mode

Warm extract air from the room flows into the unit and is cleaned in the extract filter. Then the air is moved through the heat exchangers and is exhausted outside with the extract fan. Cold fresh air from outside flows into the unit, where it is cleaned in the supply filter. Then the air flows through the heat exchanger and is directed to the room with the supply fan. Heat is exchanged between the intake and extract air in the heat exchanger. The air flows are fully separated while flowing through the heat exchanger. Heat recovery minimizes heat losses, which reduces the cost of space heating in the cold season.

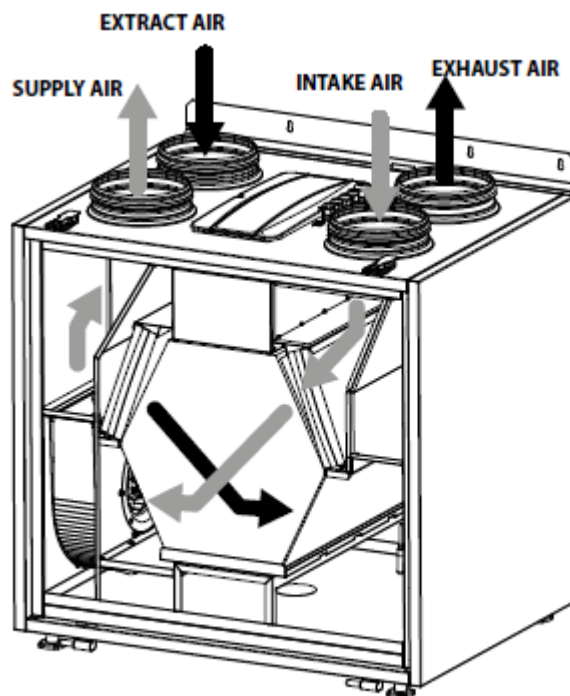

Service side view

5.2.2 Summer Cooling mode

The bypass damper is opened, the extract air that is removed from the premises is routed along the bypass duct and does not come in contact with the heat exchanger. The temperature of the air is not changed after passing through the heat exchanger.

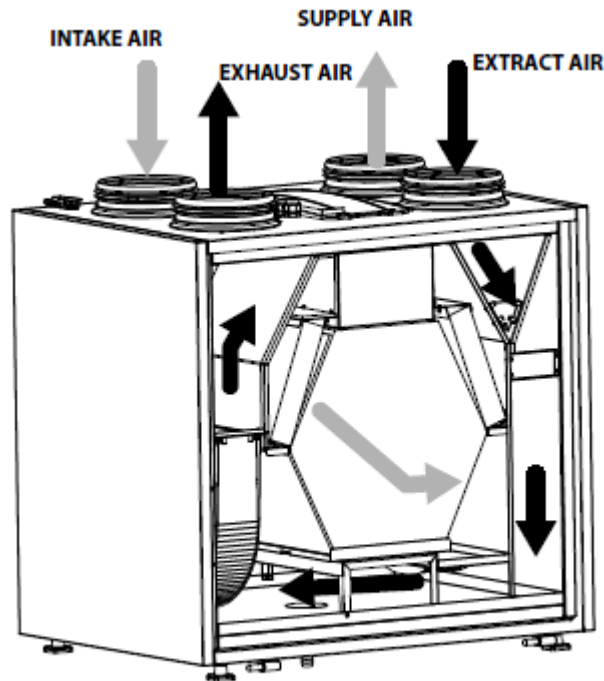

Back side view

Heat exchanger freeze protection (frost danger appears when the extract air temperature downstream of the heat exchanger is lower than +5 °C and intake air temperature upstream of the heat exchanger is lower than -3 °C for units with preheating and +3 °C for units without preheating).

There are three freeze protection modes for the MAXI (E) 160/350/550 WiFi units:

- gradual speed reduction of the supply fan
- with the help of a bypass
- with the help of electric preheating of air (if the unit is equipped with a duct preheater)

Mode selection and settings are described in the control system user's manual.

6 INSTALLATION AND SET-UP

6.1 HV2 humidity sensor installation and connection for the maxi 350/550 units

The sensor is installed before the unit mounting. Install the humidity sensor through the outlet spigot into the mount located on the wall of the exhaust air duct. Connect the humidity sensor connector to the respective connector with the cable from the control unit. Connector with the cable from the control unit is installed by the manufacturer.

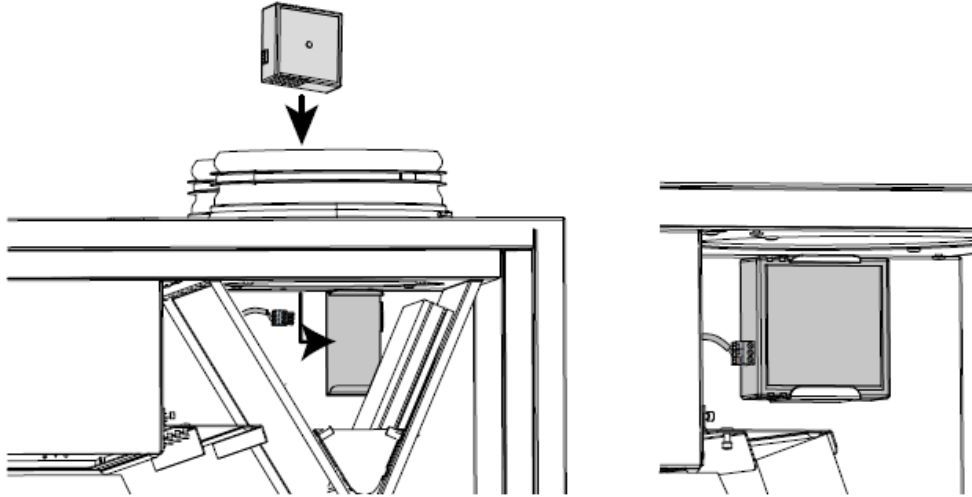

6.2 HV2 humidity sensor installation and connection for the maxi 160 units

To connect the sensor to the unit, use a cable with a connector that is included in the delivery set of the unit.

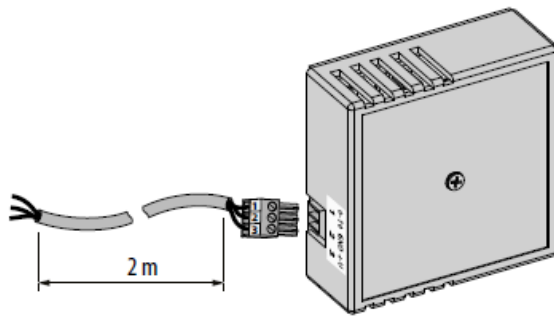

Prepare holes for mounting the sensor and for cable outlet..

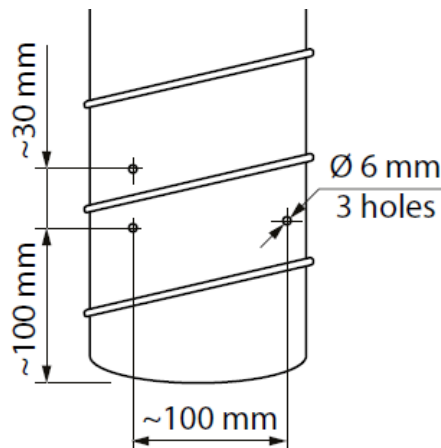

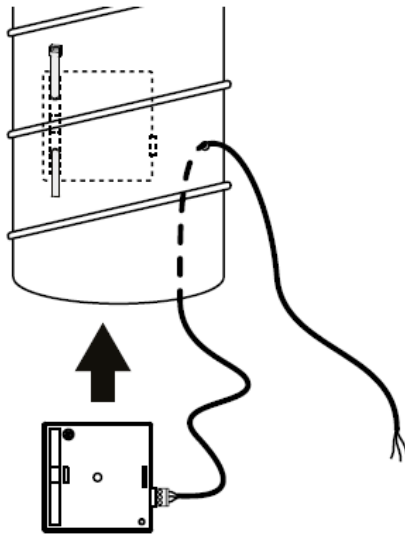

Secure the sensor with a clip on the inner side of the duct and pull the cable through the hole in the duct.
Seal connections using sealant or other materials.

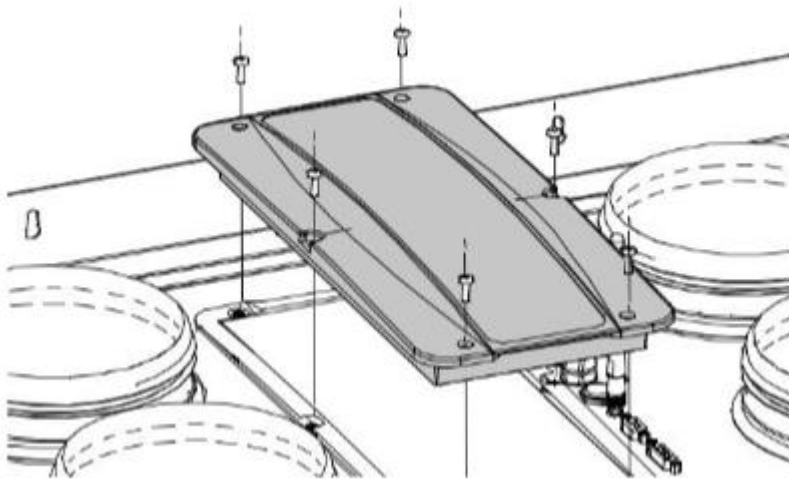

To access the control unit, remove the fixing screws and remove the cover.

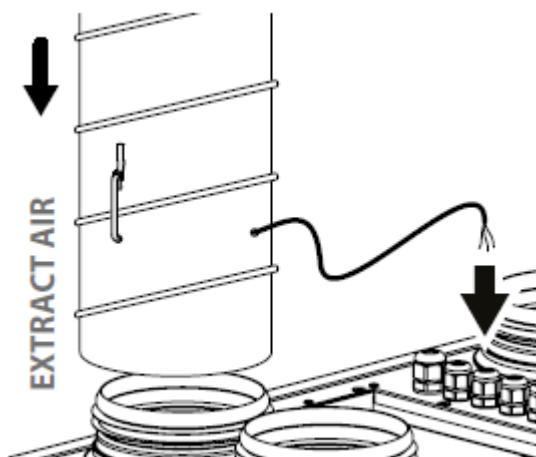

Pull the cable into the unit through the cable gland and connect it to the RH controller connector as shown in the wiring diagram of the Wireless Control System User's manual.

6.3 Service side change

The unit design allows changing the service side.

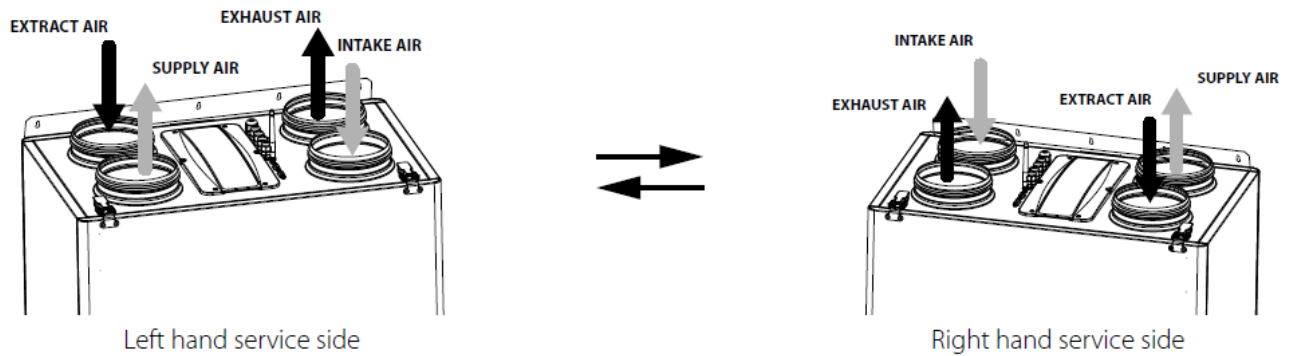

Release the latches, disconnect the ground cable and remove the service panel.

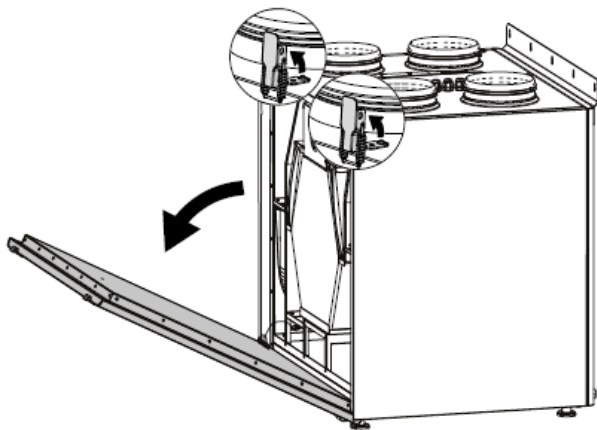

Remove the latches and move them to the opposite side. Remove the back panel by undoing the three screws hidden under plastic plugs.

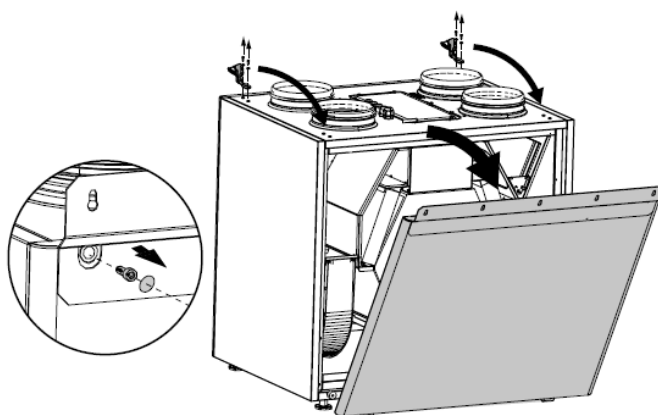

Install the back panel.

6.4 Unit installation

To get the best performance of the unit and to minimize turbulence-induced air pressure losses, connect the straight air duct section to the spigots on both sides of the unit while installing.

Minimum straight air duct length:

- equal to 1 air duct diameter on the intake side
- equal to 3 air duct diameter on the outlet side

If the air ducts are too short or not connected, protect the unit parts from ingress of foreign objects. To prevent uncontrollable access to the fans, the spigots may be covered with a protecting grille or other protecting device with mesh width not more than 12.5 mm.

When selecting the unit mounting position, enable free access to the service panel for maintenance and service operations. The unit should be mounted strictly horizontally in the longitudinal and transverse planes. In case of non-compliance, unit's casing distortion and operation disturbance will occur.

6.4.1 Unit wall mounting

Fasteners for wall mounting are not included in the delivery set and should be ordered separately.

While choosing fasteners consider the material of the mounting surface as well as the weight of the unit, refer to the "Technical data" section. Fasteners for unit mounting should be selected by the installation specialist. Install the fasteners in the wall. Suspend the unit on fasteners. Achieve a strictly vertical position of the unit by rotating the adjustable stop (1).

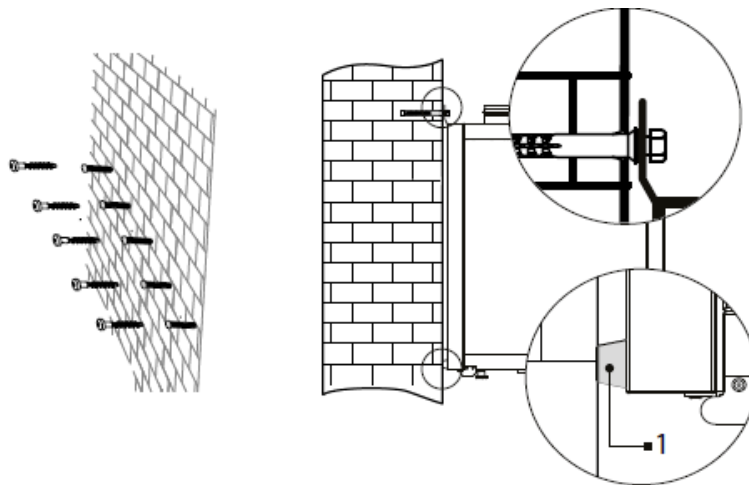

6.4.2 Unit floor mounting

Install the unit on the pre-mounted floor supports, minimum 150 mm height, to ensure sufficient access for the drain pipe connection to the U-trap and for condensate drain system installation.

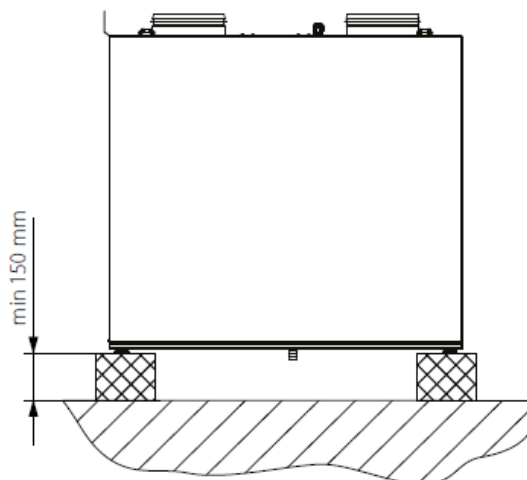

6.5 Condensate drainage

Condensate drainage is required for the MAXI 350/550 unit series.

The hole for the drain pipe is at the bottom of the unit. Remove the plug from the hole. Open the service panel and remove the plug in the drain pan. Install the drain pipe from the delivery set into the hole, then connect the drain pipe to the sewage system using the SG-32 U-trap kit (available upon separate order). Make sure the U-trap is always filled with water. The pipe slope downwards must be at least 3°.

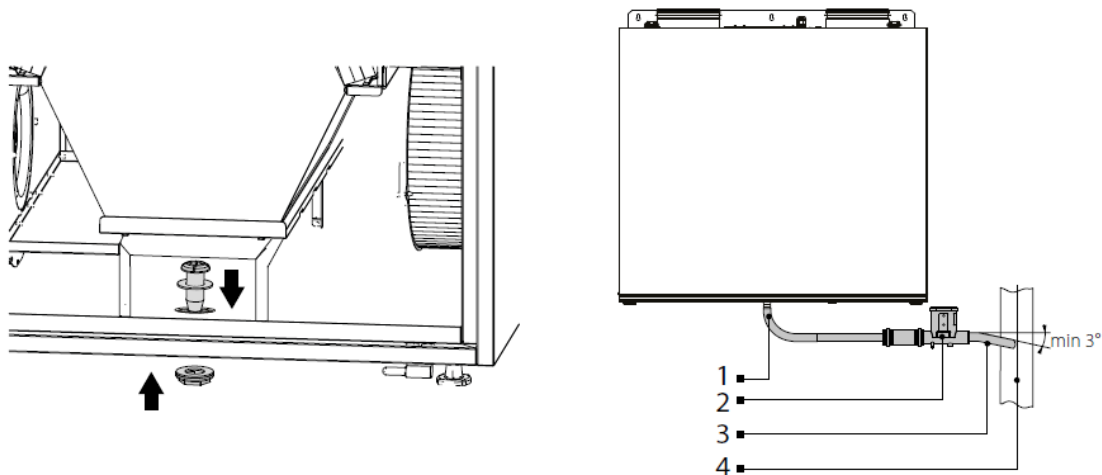

1 – drain pipe; 2 – U-trap; 3 – drain hose; 4 – sewage system

6.6 Connection to power mains



POWER OFF THE POWER SUPPLY PRIOR TO ANY OPERATIONS WITH THE UNIT.
THE UNIT MUST BE CONNECTED TO POWER SUPPLY BY A QUALIFIED ELECTRICIAN.
THE RATED ELECTRICAL PARAMETERS OF THE UNIT ARE GIVEN ON THE MANUFACTURER'S LABEL.



ANY TAMPERING WITH THE INTERNAL CONNECTIONS IS PROHIBITED AND WILL VOID THE WARRANTY.

The unit is rated for connection to 1~220-240 V/50 (60) Hz power mains.

- The unit must be connected to power mains using insulated electric conductors (cables, wires). The actual wire cross section selection must be based on the maximum load current, maximum conductor temperature depending on the wire type, insulation, length and installation method.
- The external power input must be equipped with an automatic circuit breaker built into the stationary wiring to open the electric circuit in case of overload or short-circuit. The circuit breaker installation place must provide quick access for emergency shutdown of the unit. The trip current of the automatic circuit breaker QF must exceed the maximum current consumption of the unit (refer to the technical data table). The recommended trip current of the circuit breaker is the next current in the standard trip current row following the maximum current of the connected unit. The automatic circuit breaker is not included in the delivery set.

To access the control unit, remove the fixing screws and remove the cover. The terminal block and the controller for external devices connection are located in the control unit.

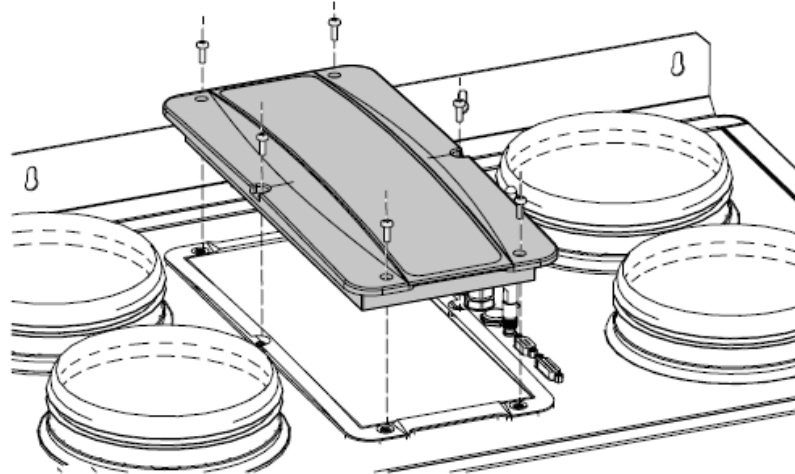

6.7 External connections diagram for the maxi 160

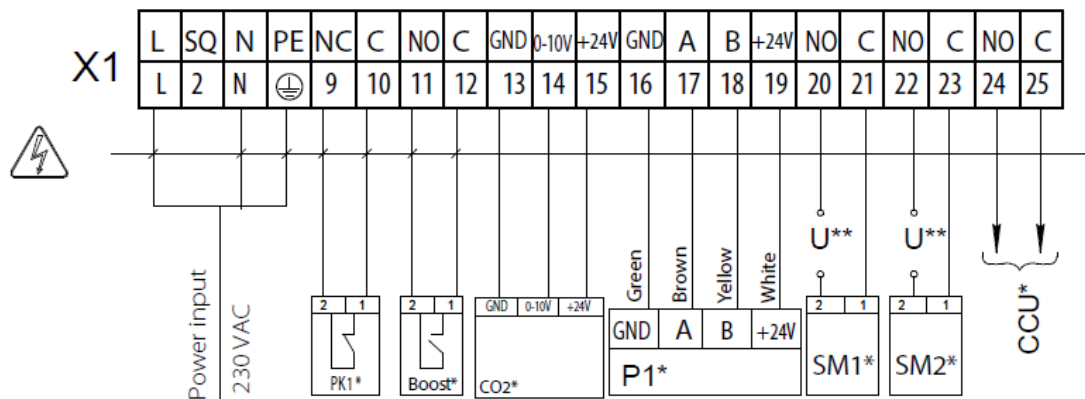

Designation	Name	Model	Wire***	Note
SM1*	Supply air damper actuator	NO	2 x 0.75 mm2	30DC/~250 AC
SM2*	Extract air damper actuator	NO	2 x 0.75 mm2	30DC/~250 AC
PK1*	Contact from fire alarm pane	NC	2 x 0.75 mm2	
CCU*	CCU control	NO	2 x 0.75 mm2	30DC/~250 AC
P1*	External control panel		4 x 0.25 mm2	
Boost***	On/Off contacts for the Boost mode	NO	2 x 0.75 mm2	
CO2*	External CO2 sensor		3 x 0.25 mm2	

*Is not included in the delivery set.

** The U supply voltage of the SM1, SM2 external dampers is selected depending on the type of dampers.

*** Maximum connecting cable length is 20 m!

Output parameters: terminals 20-25 - 3A, 30VDC / ~ 250 VAC (“dry contact”).

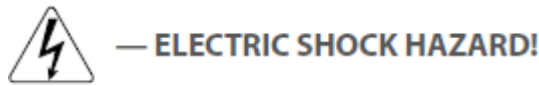

6.8 External connections diagram for the maxi 350/550

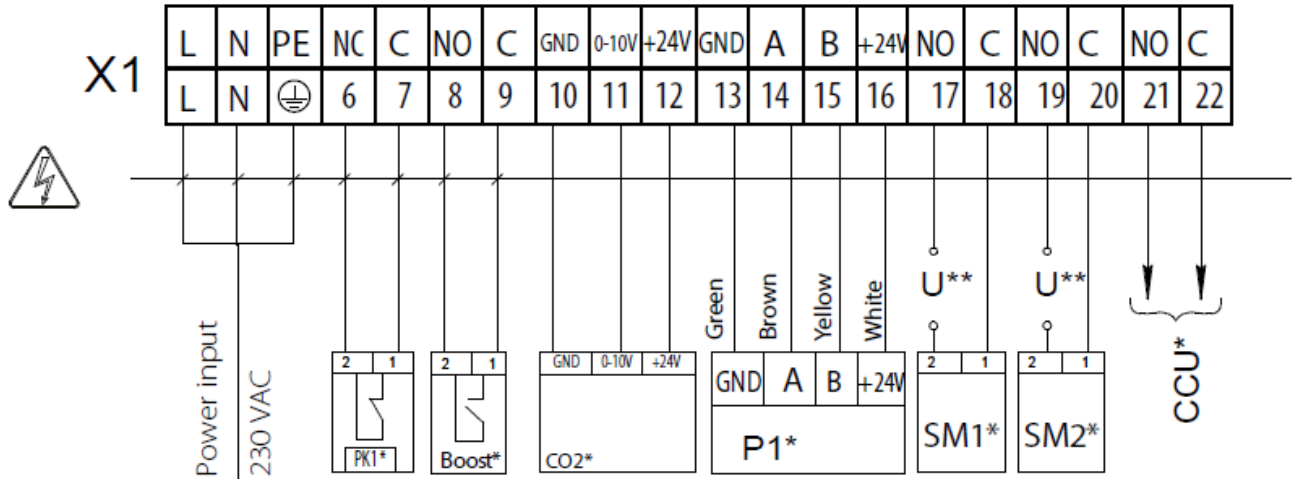

Designation	Name	Model	Wire***	Note
SM1*	Supply air damper actuator	NO	2 x 0.75 mm2	30DC/~250 AC
SM2*	Extract air damper actuato	NO	2 x 0.75 mm2	30DC/~250 AC
PK1*	Contact from fire alarm pane	NC	2 x 0.75 mm2	
CCU*	CCU control	NO	2 x 0.75 mm2	30DC/~250 AC
P1*	External control panel		4 x 0.25 mm2	
Boost***	On/Off contacts for the Boost mode	NO	2 x 0.75 mm2	
CO2*	External CO2 sensor		3 x 0.25 mm2	

*Is not included in the delivery set.

** The U supply voltage of the SM1, SM2 external dampers is selected depending on the type of dampers.

*** Maximum connecting cable length is 20 m!

Output parameters: terminals 17-22 - 3A, 30VDC / ~ 250 VAC (<<dry contact>>).

7 TECHNICAL MAINTENANCE



DISCONNECT THE UNIT FROM POWER SUPPLY BEFORE ANY MAINTENANCE OPERATIONS!

Maintenance operations of the unit are required 3-4 times per year. They include general cleaning of the unit and the following operations:

1. Filter maintenance (3-4 times per year).

Dirty filters increase air resistance in the system and reduce supply air volume. The filters require cleaning not less than 3-4 times per year.

Clean the filter with a vacuum cleaner or replace it with a new one. For new filters contact the Seller.

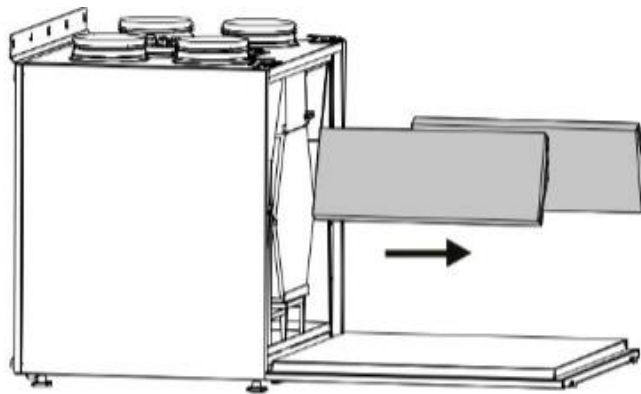

2. Heat exchanger maintenance (once per year).

Some dust may accumulate on the heat exchanger even in case of regular maintenance of the filters. To maintain the high heat recovery efficiency, regular cleaning is required. To clean the heat exchanger, remove it from the unit and clean the heat exchanger by using compressed air or a vacuum cleaner. In case of severe contamination, the heat exchanger can be washed with water. After cleaning, reinstall the heat exchanger into the unit.

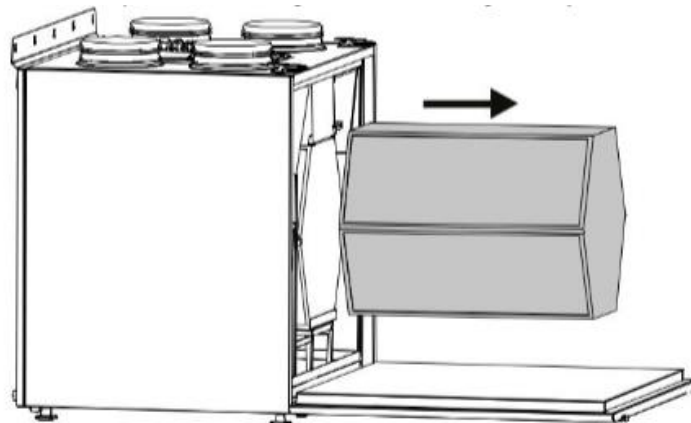

3. Fan maintenance (once per year).

Even in case of regular maintenance of the filters, some dust may accumulate inside the fans and reduce the fan performance and supply air flow. Fans should be cleaned by the service technician.

4. Condensate drainage system maintenance (4 times per year).

The condensate drainage (drain line) may get clogged by dirt and dust particles contained in the exhaust air. Check the drain line operation by filling the drain pan under the unit with water, clean the U-trap and the drain line, if necessary.

5. Supply air flow control (twice per year).

The supply duct grille may get clogged with leaves and other objects reducing the unit performance and supply air delivery. Check the supply grille twice per year and clean it as required.

6. Ductwork system maintenance (once in 5 years).

Even regular fulfilling of all the maintenance operations prescribed above may not completely prevent dirt accumulation in the air ducts, which leads to air pollution and reduces the unit capacity. Duct maintenance means regular cleaning or replacement.



IF UNIDENTIFIED NOISES OR ODOURS SHOULD ARISE AND IN CASE OF DEFORMATION OF ELEMENTS, VIBRATION, TERMINATION OF AIR SUPPLY/EXTRACTION OR REDUCED SYSTEM PERFORMANCE, IMMEDIATELY DISCONNECT THE UNIT FROM POWER SUPPLY AND CONTACT THE SELLER FOR THE VENTILATION SYSTEM DIAGNOSTICS. DIAGNOSTICS MUST BE CARRIED OUT BY QUALIFIED SPECIALISTS.

7.1 Possible reasons and troubleshooting

Problem	Possible reasons	Troubleshooting
The fan(s) does not start when the unit is on.	No power supply.	Make sure the power supply line is connected correctly, otherwise troubleshoot the connection error. Change the mode with the help of the control panel.
	The mode in which the fans are turned off is set.	
Low air flow.	Low set fan speed.	Set higher speed.
	The filters and the fans are clogged, the heat exchanger is clogged.	Clean or replace the filters, clean the fans and the heat exchanger.
	Ventilation system elements (air ducts, diffusers, louver shutters, grilles) are clogged, damaged or closed.	Clean or replace the ventilation system elements, such as air ducts, diffusers, louver shutters, grilles.
Cold supply air.	The extract filter is soiled.	Clean or replace the extract filter.
Noise, vibration.	The fan or casing screw connection is loose.	Tighten the screw connection of the fans or the casing.
	No anti-vibration connectors on air duct pipe flanges.	Install anti-vibration connectors.

If troubleshooting steps have failed, contact the Seller of the product. In case of faults not described in the table, contact the Seller for further information.

8 STORAGE AND TRANSPORTATION REGULATIONS

- Store the unit in the manufacturer's original packaging box in a dry closed ventilated premise with temperature range +5 °...+40 °C and relative humidity up to 70 %.
- Storage environment must not contain aggressive vapors and chemical mixtures provoking corrosion, insulation, and sealing deformation.
- Use suitable hoist machinery for handling and storage operations to prevent possible damage to the unit.
- Follow the handling requirements applicable for the particular type of cargo.
- The unit can be carried in the original packaging by any mode of transport provided proper protection against precipitation and mechanical damage. The unit must be transported only in the working position.
- Avoid sharp blows, scratches, or rough handling during loading and unloading.
- Prior to the initial power-up after transportation at low temperatures, allow the unit to warm up at operating temperature for at least 3-4 hours.

9 MANUFACTURER'S WARRANTY

The product is in compliance with EU norms and standards on low voltage guidelines and electromagnetic compatibility. We hereby declare that the product complies with the provisions of Electromagnetic Council Directive 2014/30/EU, Low Voltage Directive 2014/35/EU and CE-marking Directive 93/68/EEC. This certificate is issued following test carried out on samples of the product referred to above.

The manufacturer hereby warrants normal operation of the unit for 24 months after the retail sale date provided the user's observance of the transportation, storage, installation, and operation regulations. Should any malfunctions occur in the course of the unit operation through the Manufacturer's fault during the guaranteed period of operation, the user is entitled to get all the faults eliminated by the manufacturer by means of warranty repair at the factory free of charge. The warranty repair includes work specific to elimination of faults in the unit operation to ensure its intended use by the user within the guaranteed period of operation. The faults are eliminated by means of replacement or repair of the unit components or a specific part of such unit component.

The warranty repair does not include:

- routine technical maintenance
- unit installation/dismantling
- unit setup

To benefit from warranty repair, the user must provide the unit, the user's manual with the purchase date stamp, and the payment paperwork certifying the purchase. The unit model must comply with the one stated in the user's manual. Contact the Seller for warranty service.

The manufacturer's warranty does not apply to the following cases:

- User's failure to submit the unit with the entire delivery package as stated in the user's manual including submission with missing component parts previously dismantled by the user.
- Mismatch of the unit model and the brand name with the information stated on the unit packaging and in the user's manual.
- User's failure to ensure timely technical maintenance of the unit.
- External damage to the unit casing (excluding external modifications as required for installation) and internal components caused by the user.
- Redesign or engineering changes to the unit.
- Replacement and use of any assemblies, parts and components not approved by the manufacturer.
- Unit misuse.
- Violation of the unit installation regulations by the user.
- Violation of the unit control regulations by the user.
- Unit connection to power mains with a voltage different from the one stated in the user's manual.
- Unit breakdown due to voltage surges in power mains.
- Discretionary repair of the unit by the user.
- Unit repair by any persons without the manufacturer's authorization.
- Expiration of the unit warranty period.
- Violation of the unit transportation regulations by the user.
- Violation of the unit storage regulations by the user.
- Wrongful actions against the unit committed by third parties.
- Unit breakdown due to circumstances of insuperable force (fire, flood, earthquake, war, hostilities of any kind, blockades).
- Missing seals if provided by the user's manual.
- Failure to submit the user's manual with the unit purchase date stamp.
- Missing payment paperwork certifying the unit purchase ANC



FOLLOWING THE REGULATIONS STIPULATED HEREIN WILL ENSURE A LONG AND TROUBLE-FREE OPERATION OF THE UNIT.



USER'S WARRANTY CLAIMS SHALL BE SUBJECT TO REVIEW ONLY UPON PRESENTATION OF THE UNIT, THE PAYMENT DOCUMENT AND THE USER'S MANUAL WITH THE PURCHASE DATE STAMP.

9.1 Certificate of acceptance

Unit Type	Heat and energy recovery air handling unit
Model	MAXI _____
Serial Number	
Manufacture Date	
Quality Inspector's Stamp	

9.2 Seller informations

Seller:

ORCA ENERGIJA d.o.o.
Vodovodna ulica 30c
2000 Maribor, Slovenija

Signature:

Installation technicians informations:

Signature:

(name)

(Address)

Installation date: _____

